

Universal Mains Input Audio SMPS

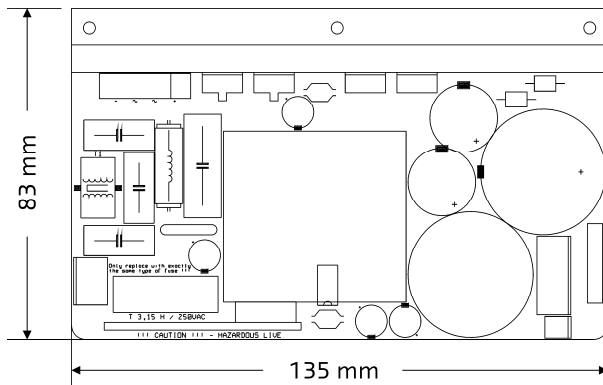

Highlights

- High efficiency
- Universal mains input voltage
- Near unity Power Factor
- Low EMI

Features

- Advanced over current protection
- Remote controlled operation
- Low weight: 400 gr.
- Compact: 135 x 83 x 49mm
- Adjustable output voltage

Applications

- Supply for single or multiple amplifiers of the UcD™ range
- Active loudspeakers

Description

The SMPS180 is a high efficiency Safety Class 2 switch mode power supply specifically designed for use with our range of UcD™ amplifier modules. Key features are high efficiency over the entire load range, universal input voltage range (85 – 264V, 50 - 60Hz), near unity Power Factor, low weight and very low radiated and conducted EMI. The SMPS180 also features an advanced overcurrent protection which in case of temporary overload simply reduces the output voltage, only when the overload condition remains for a longer time the supply will enter hiccup mode until the overload condition disappears. This feature in combination with the advanced feedback topology and large secondary bulk storage output caps leads to the capability of delivering high dynamic headroom power to the connected amplifier. The SMPS180 also includes an auxiliary isolated $\pm 12V$ supply and a control circuit directly interfacing with our range of (OEM and standard) UcD™ amplifier modules. The supply is triggered for normal operation or latched off in case of critical fault via in built-in actuators. The SMPS180 is optimized from the first phase of design to final implementation to realize the low EMI signature required of the most demanding audio applications.

Principle of operation

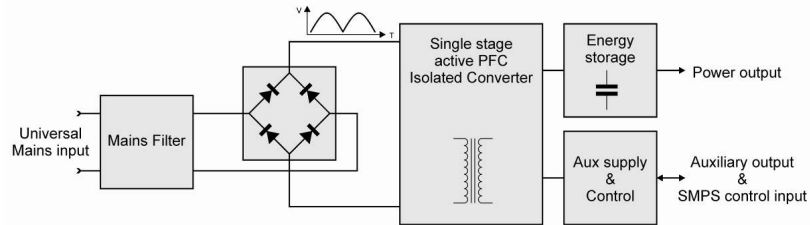

Conventional Switch Mode Power Supplies so commonly unsuitable for audio purposes typically realize active Power Factor Correction and regulation with multiple stages while the bulk of stored energy is placed at the input, far from the load.

The Hypex SMPS180 achieves the above useful features in a single optimized power conversion stage, however more in line with non-switching unregulated supplies so popular in audio, in order to best satisfy sudden demanding load transients, converted energy is fully stored on the galvanically isolated secondary side bulk capacitors, closest to the load itself.

Safety precautions



The SMPS180 operates at mains voltage and carries hazardous voltages at accessible parts. These parts may never be exposed to inadvertent touch. Observe extreme care during installation and never touch any part of the unit while it is connected to the mains. Disconnect the unit from the mains and allow all capacitors to discharge for 5 minutes before handling it.

This product has no servicable parts other than the on-board fuse. Replace the fuse only with the same type and rating (T3,15H).

This is a Safety Class 2 device. It is very important to maintain a 6mm clearance with all possible conducting parts (housing etc.) and cables. All parts enclosed by the dotted line below carry hazardous voltages. This includes parts on the top and the bottom of the board as well as all parts on the vertical board. When the SMPS180 is mounted in a tight space there needs to be at least 6mm clearance or a layer of insulation with a minimum thickness of 4mm between the top of the transformer and the housing.



accessible live parts !
These parts may never be exposed to inadvertent touch.

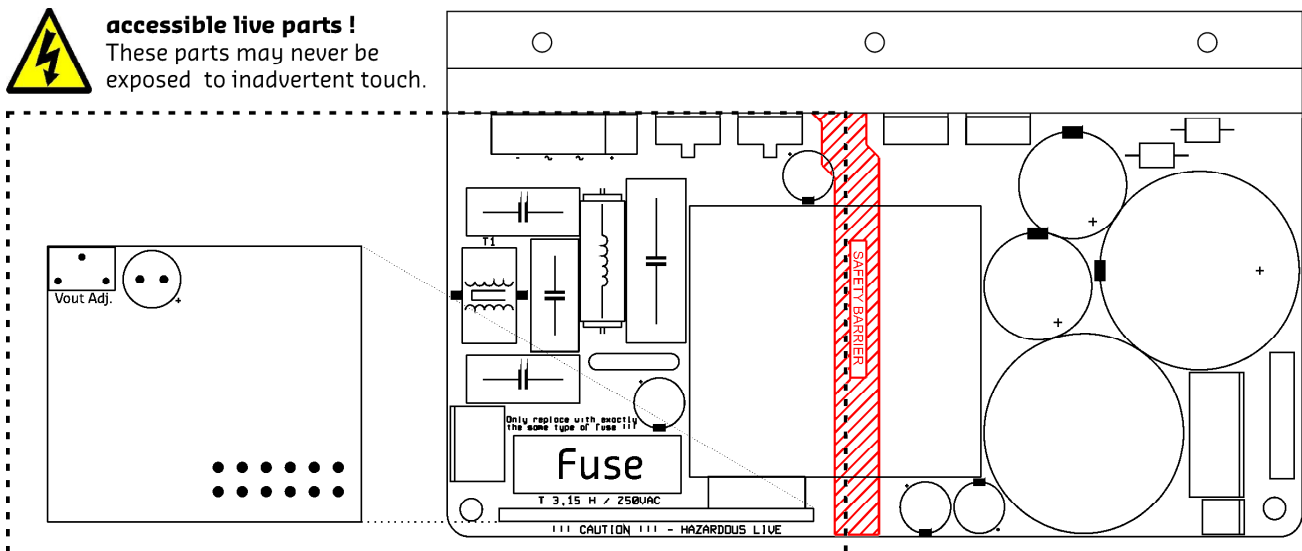

Absolute maximum ratings

Correct operation at these limits is not guaranteed. Operation beyond these limits may result in irreversible damage

Item	Symbol	Rating	Unit	Notes
Input voltage	V_{LINE}	264	Vac	
Air Temperature	T_{AMB}	50	°C	Power output is reduced
Heat-sink temperature	T_{SINK}	95	°C	

Recommended Operating Conditions

Item	Symbol	Min	Typ	Max	Unit	Notes
Operating Line Input Voltage	V_B	85		264	Vac	
Full Power Operating Input Voltage	$V_{B,FP}$	100		264	Vac	

General Performance data

Item	Symbol	Min	Typ	Max	Unit	Notes
Output Voltage	V_{OUT}	2 x 35		2 x 45	Vdc	See Note 4
Output Current	I_{OUT}		3.4		A	See Note 3
Regulated Output Voltage Aux	$V_{OUT,AUX,REG}$		2 x 12		Vdc	
Unregulated Output Voltage Aux	$V_{OUT,AUX,UNREG}$	2 x 14		2 x 18	Vdc	See Note 5
Output Current Aux	$I_{OUT,AUX}$		250m		A	per rail
Output Power	P_R	300	-	-	W	See Note 1
Audio Output Power @ 20Hz into amplifier load	P_{RALF}	180	-	-	W	See Note 2
Efficiency	η		TBD		%	full power
Idle Losses	P_0		2		W	
Standby Power	$P_{standby}$		TBD		W	
Switching frequency	F_{SW}		100		kHz	
Line regulation			TBD			%
Load regulation			TBD			%

Note 1: Output Power delivered to a resistive dummy load (generally the only specification supplied by other SMPS manufacturers).

Note 2: An audio amplifier actually draws twice the RMS power from the power supply. At high frequencies the secondary storage output caps are capable to provide this power. At very low frequencies however the SMPS is responsible for delivering this peak power to the amplifier.

Note 3: Both rails loaded. Maximum current per rail is 6.7A (one rail loaded).

Note 4: Adjustable by means of a potentiometer.

Note 5: This output voltage is proportional to main outputs Vcc and Vee respectively.

Output Power Performance data

The SMPS180 is designed for music reproduction and is therefore not able to deliver its maximum output power long-term. The RMS value of any common music signal generally doesn't exceed 1/8th of the maximum peak power. The SMPS180 is therefore perfectly capable of driving the connected amplifier in clipping continuously with a music signal without the need of additional external cooling.

Unless otherwise specified. $T_a = 25^\circ\text{C}$. Connected amplifier: UcD1800EMV2, $f = 1\text{kHz}$. SMPS180 is horizontally mounted in free air without additional external cooling. The SMPS180 was preheated at $1/8P_R$ (23W @ 1kHz into 4 Ohm amplifier load).

Item	Symbol	Conditions	Min	Typ	Max	Unit	Notes
Amplifier output power for 10 sec. until $T_{\text{MOSFET}} = 100^\circ\text{C}$	P_o	Load = 4Ω 100Vac/60Hz 230Vac/50Hz		180 180		W	20 sec.
Amplifier output power for 1 min. until $T_{\text{MOSFET}} = 100^\circ\text{C}$	P_o	Load = 4Ω 100Vac/60Hz 230Vac/50Hz		90 100		W	
Amplifier output power for 5 min. until $T_{\text{MOSFET}} = 100^\circ\text{C}$	P_o	Load = 4Ω 100Vac/60Hz 230Vac/50Hz		70 80		W	
Continuous output power. T_{MOSFET} stabilized at 100°C	P_o	Load = 4Ω 100Vac/60Hz 230Vac/50Hz		50 60		W	

Unless otherwise specified. $T_a = 25^\circ\text{C}$. Connected amplifier: UcD1800EMV2, $f = 1\text{kHz}$. SMPS180 is horizontally mounted in free air mounted to 400cm² aluminium additional external cooling. The SMPS180 was preheated at $1/8P_R$ (23W @ 1kHz into 4 Ohm amplifier load).

Item	Symbol	Conditions	Min	Typ	Max	Unit	Notes
Amplifier output power for 10 sec. until $T_{\text{MOSFET}} = 100^\circ\text{C}$	P_o	Load = 4Ω 100Vac/60Hz 230Vac/50Hz		180 180		W	15 sec. 30 sec.
Amplifier output power for 1 min. until $T_{\text{MOSFET}} = 100^\circ\text{C}$	P_o	Load = 4Ω 100Vac/60Hz 230Vac/50Hz		110 150		W	
Amplifier output power for 5 min. until $T_{\text{MOSFET}} = 100^\circ\text{C}$	P_o	Load = 4Ω 100Vac/60Hz 230Vac/50Hz		100 120		W	
Continuous output power. T_{MOSFET} stabilized at 100°C	P_o	Load = 4Ω 100Vac/60Hz 230Vac/50Hz		90 100		W	

J1: Auxiliary Output Connections. Connector type: JST-B7B-EHA

Pin	Function
1	SMPS Standby
2	Amplifier Standby
3	Positive Unregulated Auxiliary Output Voltage
4	Positive Regulated Auxiliary Output Voltage
5	Ground
6	Negative Regulated Auxiliary Output Voltage
7	Negative Unregulated Auxiliary Output Voltage

J2: Main Output Connections. Connector type: JST-B5P-VH

Pin	Function
1	Positive Output Voltage (Vcc)
2	Output Ground
3	Negative Output Voltage (Vee)
4	DC Error Input (OEM amplifier series only)
5	Auto Amplifier Enable

J4: Mains Input. Connector type: JST-B3P-VH

Pin	Function
1, 3	Mains Input
2	*

* As per Class 2 ground is NC and so unavailable for safety ground. You must follow Class 2 safety standards in implementing the SMPS180. Also read <http://www.hypex.nl/docs/earth.pdf>

J5: DC Error In. Connector type: 2-pin MOLEX® KK® series

Pin	Function
1	DC Error Input 1 (UcD-series ST/HG or generic amplifier)
2	DC Error Input 2 (UcD-series ST/HG or generic amplifier)

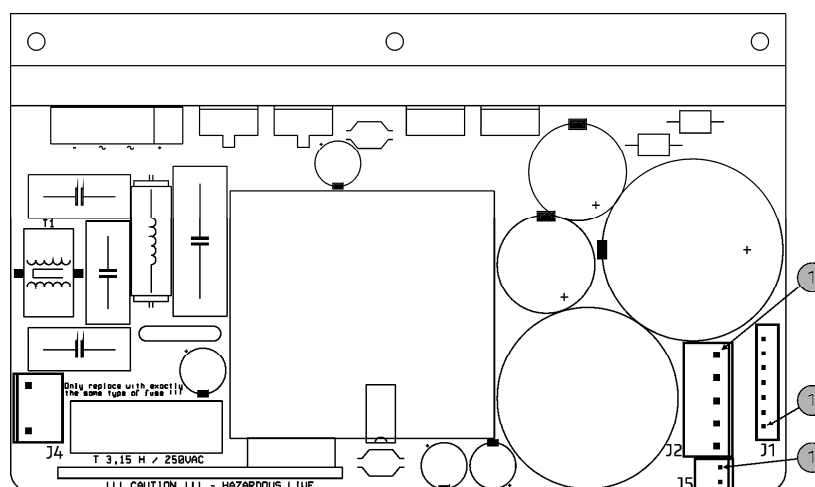

Fig1. Connector pinning SMPS180.

SMPS Standby Input Characteristics

Applying an external DC voltage to this input will put the SMPS in standby. Both main and auxiliary output voltages will drop gradually. Removing the standby voltage will result in a normal soft started start-up of the SMPS180.

Item	Type	Min	Typ	Max	Unit	Notes
DC voltage on J1:1	input	3,3		12	Vdc	

Amplifier Standby Input Characteristics

Applying an external DC voltage to the amplifier standby pin will put the amplifier in standby. The connected amplifier must be connected to Auto Amplifier Enable, described below, in order to use this option.

Item	Type	Min	Typ	Max	Unit	Notes
DC voltage on J1:2	input	0		Vcc	Vdc	

Unregulated Auxiliary Output Characteristics

The SMPS180 provides Unregulated Aux Outputs to enable the user to create one's own external regulation.

Item	Type	Min	Typ	Max	Unit	Notes
Positive DC voltage on J1:3	output	14		18	Vdc	See note 1
Negative DC voltage on J1:7	output	14		18	Vdc	See note 1

Note 1: These outputs are proportional with Vcc/Vee.

Regulated Auxiliary Output Characteristics

The SMPS180 provides Regulated Auxiliary Output Voltages that are available for external auxiliary purposes.

Item	Type	Min	Typ	Max	Unit	Notes
Positive DC voltage on J1:4	output	11	11,5	12	Vdc	See note 1
Negative DC voltage on J1:6	output	11	11,5	12	Vdc	See note 1

Note 1: These outputs are short term shortcut protected (2 sec.)

Output Voltage Characteristics

Item	Type	Min	Typ	Max	Unit	Notes
Positive DC voltage on J2:1	Output	35		45	Vdc	See note 1,2
Negative DC voltage on J2:3	Output	35		45	Vdc	See note 1,2

Note 1: Output voltage is user adjustable by adjusting the blue potentiometer on the vertical board located near the fuse holder.



The vertical board carries hazardous live voltages. Extreme care should be taken to protect against electrical shock. Adjust the potentiometer slowly with a non-conductive trimmer and do not hold the board with the other hand inadvertently.

Note 2: These outputs are fully long term shortcut protected: outputs to ground, output to output.

Output Grounds Characteristics

The Output Ground reference. Main Output Ground and Auxiliary Output Ground are connected together on the board.

DC Error Input Characteristics

In the event of a critical failure occurring in the connected amplifier which may cause damage to the connected loudspeaker, the SMPS180 needs to be switched-off rapidly. The SMPS180 provides a single DC Error Input designated for a UcD OEM series amplifier. The DC Error Input is latched and will not auto-recover. The SMPS180 needs to be disconnected from the mains a couple of seconds to reset.

Item	Type	Min	Typ	Max	Unit	Notes
DC voltage on J2:4	Input				Vdc	*Use open collector

* Pin 33 of the 36-pin connector on the UcD180OEM/UcD400OEM or pin 8 of the 14-pin connector on the UcD100OEM needs to be connected to this pin to enable this function. Multiple modules can be connected to this pin.

Auto Amplifier Enable Characteristics

When the enable-line of a UcD-series amplifier is connected to this pin the amplifier will be enabled and disabled automatically when the SMPS180 is switched on and off.

Item	Type	Min	Typ	Max	Unit	Notes
DC voltage on J2:5	Output					Internal open collector

DC Error Input 1,2 Characteristics

In the event of a critical failure occurring in the connected amplifier which may cause damage to the connected loudspeaker, the SMPS180 needs to be switched-off rapidly. The SMPS180 provides double generic DC Error Inputs. These DC Error Inputs are latched and will not auto-recover. The SMPS180 needs to be disconnected from the mains a couple of seconds to reset. A total of two modules can be connected.

Item	Type	Min	Typ	Max	Unit	Notes
DC voltage on J5:1,2	Input					*

* The positive loudspeaker output of a UcD-series ST/HG or generic amplifier needs to be connected to either J5:1 or J5:2 to enable this function.

Dimensions. Top view.

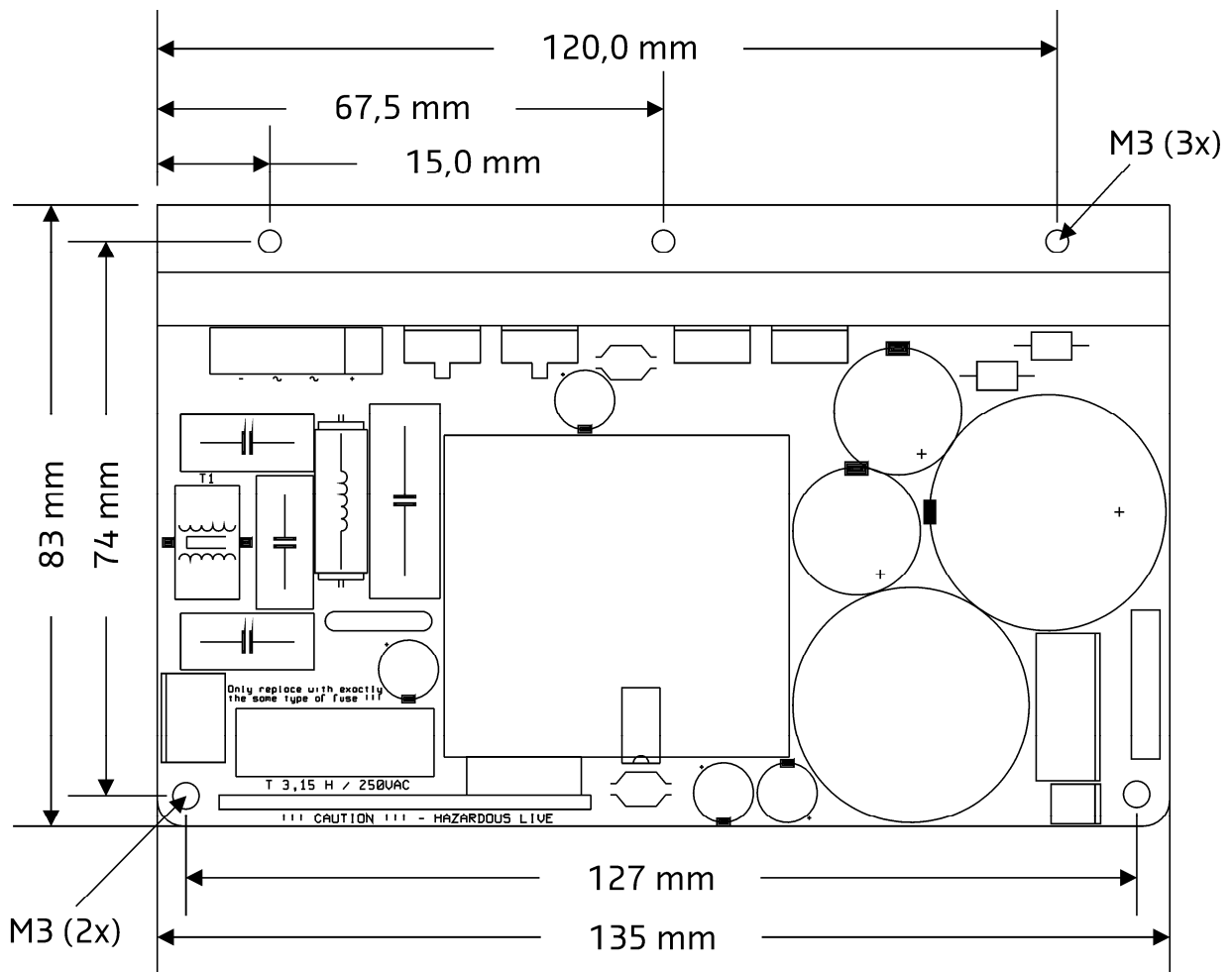

Dimensions. Side view.

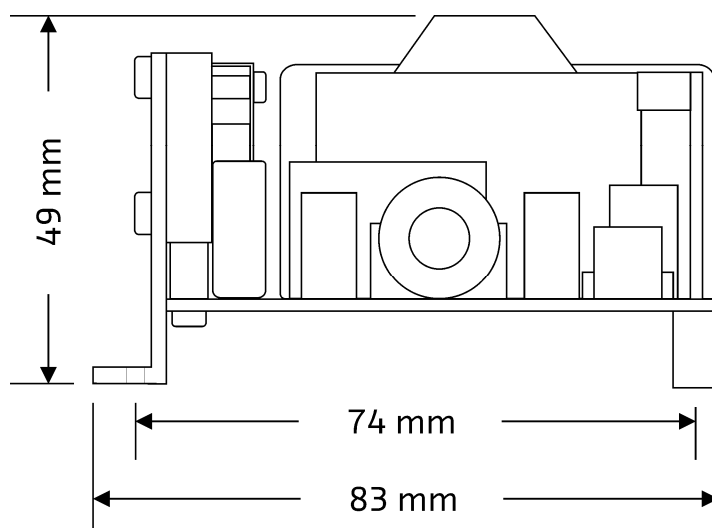

Document Revision	PCB Version	Description	Date
R1	SMPS180V2	Initial Draft.	14.08.2008
R2	SMPS180V3	- Thermal protection added. - Short circuit protection added.	01.09.2008
R3	SMPS180V4	- Input connector moved towards sink. - Short circuit protection improved. - EMI behaviour further improved.	12.02.2009