

## High Efficiency Power Amplifier Module

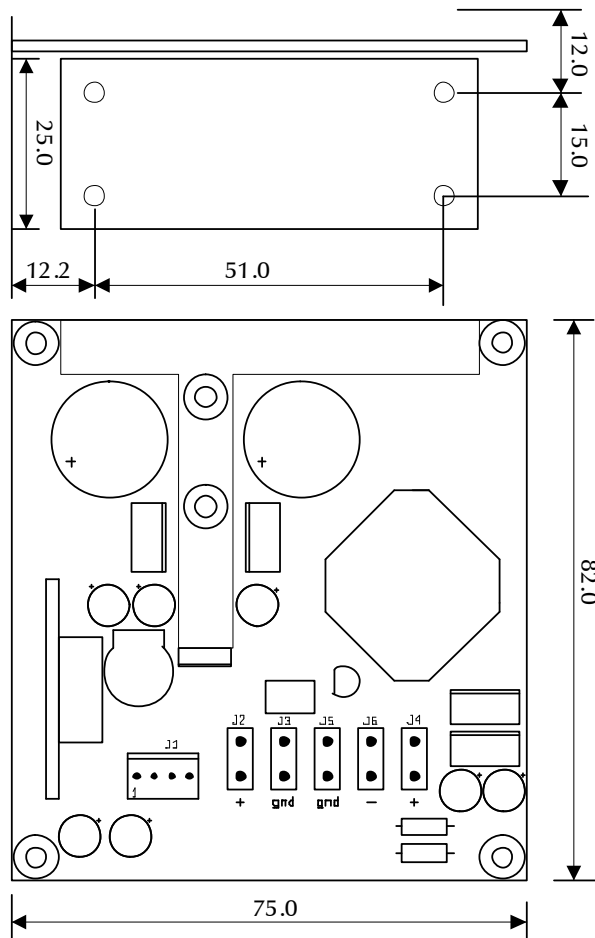

### Highlights

- Flat, fully load-independent frequency response
- Low output impedance
- Very low, frequency-independent THD
- Very low noise
- Fully passive loop control
- Consistent top performer in listening trials

### Features

- Runs on unregulated +/- rails
- Pop-free start and stop control
- Differential audio input
- Overcurrent and overvoltage protection
- Weight: 160gms (5.5oz.)

### Applications

- Monitor loudspeakers for recording and mastering studios
- Audiophile power amplifiers for professional and consumer use
- Public Address systems
- Home theatre systems
- Active loudspeakers

## Description

The UcD400™ amplifier module is a self-contained high-performance class D amplifier intended for a wide range of audio applications, ranging from Public Address systems to ultrahigh-fidelity replay systems for studio and home use. Chief distinguishing features are flat frequency response irrespective of load impedance, nearly frequency-independent distortion behaviour and very low radiated and conducted EMI. Control is based on a phase-shift controlled self-oscillating loop taking feedback only at the speaker output.

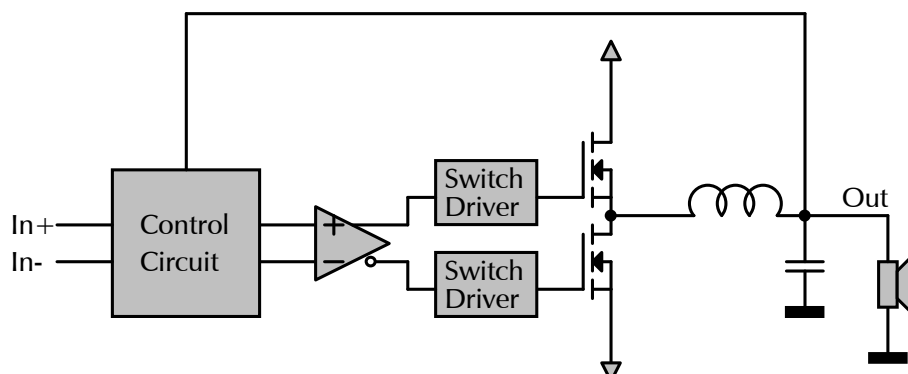

## Performance data

Power supply = +/-65V, Load=4Ω, MBW=40kHz, unless otherwise noted

Item	Symbol	Min	Typ	Max	Unit	Notes
Output Power	$P_R$	400	-	-	W	THD=1%
Distortion	THD+N	-	0.01	0.05	%	20Hz<f<20kHz. Pout<P <sub>R</sub> /2
		-	-	0.004	%	20Hz<f<20kHz Pout=1W
Output noise	$U_N$	-	30μ	35μ	V	Unwtd, 20Hz-20kHz
Output Impedance	$Z_{OUT}$	-	-	20m	Ω	f<1kHz
		-	-	150m	Ω	f<20kHz
Power Bandwidth	PBW		20-35k		Hz	
Frequency Response		10	-	50k	Hz	+0/-3dB. All loads.
Voltage Gain	$A_V$	25.5	26	26.5	dB	
Supply Ripple Rejection	PSRR		65		dB	Either rail, all frequencies.
Efficiency	$\eta$		92		%	Full power
Idle Losses	$P_0$		8		W	
Standby Current	$I_{STBY}$		10m		A	
Current Limit			20		A	Stop mode after limiting 40ms

## Absolute maximum ratings

Correct operation at these limits is not guaranteed. Operation beyond these limits may result in irreversible damage

Item	Symbol	Rating	Unit	Notes
Power supply voltage	$V_R$	+/-75	V	Unit shuts down when either rail exceeds 68V
Peak output current	$I_{OUT,P}$	21	A	Unit current-limits at 20A
Input voltage	$V_{IN}$	+/-12	V	Either input referred to ground
Air Temperature	$T_{AMB}$	65	°C	
Heat-sink temperature	$T_{SINK}$	90	°C	User to select heat sink to insure this condition under most adverse use case

## Recommended Operating Conditions

Item	Symbol	Min	Typ	Max	Unit	Notes
Power supply voltage	$V_R$	45	57	65	V	
Load impedance	$Z_{LOAD}$	1			Ω	
Source impedance	$Z_{SRC}$			7k	Ω	Differential. Corresponds to 3dB noise increase.
Effective power supply storage capacitance	$C_{SUP}$	4700μ			F	Per rail, per attached amplifier. 4Ω load presumed.

## Connections

### J1: Input and ON/OFF control

Connector type: 4-pin MOLEX® KK® series.

Pin	Function
1	Noninverting Audio Input
2	GND
3	Inverting Audio Input
4	ON/OFF control

### Input Characteristics

Item	Symbol	Min	Typ	Max	Unit	Notes
Input Impedance	$Z_{in}$		100k		$\Omega$	Either input to ground
Common Mode Rejection Ratio	CMRR		45		dB	All frequencies
Control voltage on pin 4, amplifier ON				3	V	
Control voltage on pin 4, amplifier OFF		12			V	Internally pulled up to 15V

Note: It is recommended to use an open collector output to control the on/off pin.

### J2: Loudspeaker output (hot)

Connector type: ¼" FASTON® tab.

### J3: Loudspeaker output (cold)

Connector type: ¼" FASTON® tab.

Internally connected to GND. Note: This is the feedback reference. For best performance, do not use another ground connection for the loudspeaker.

### J4: Positive power supply connection, +VB

Connector type: ¼" FASTON® tab.

### J5: Power supply ground connection, GND

Connector type: ¼" FASTON® tab.

### J6: Negative power supply connection, -VB

Connector type: ¼" FASTON® tab.

## Typical Performance Graphs

### THD vs. Power (1kHz, 4Ω)

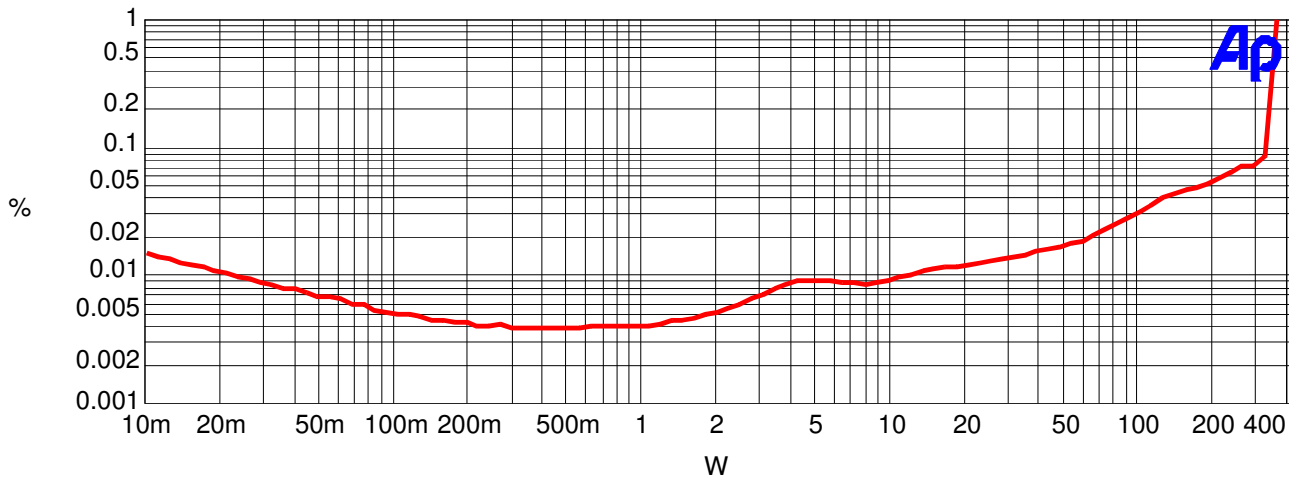

### THD vs. Frequency (8Ω)

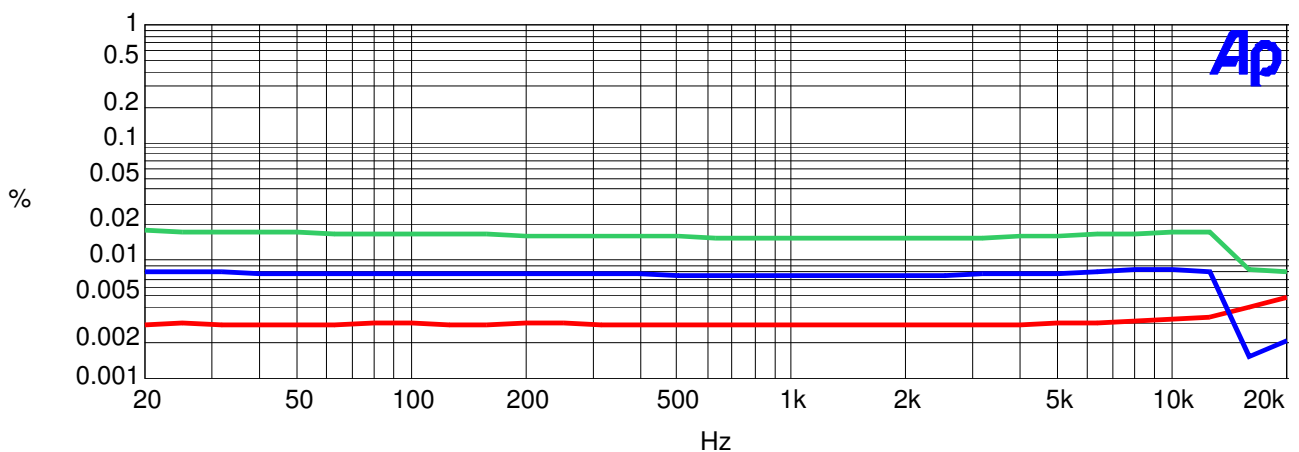

From top to bottom: 40W, 10W, 1W

### Frequency Response (4Ω, 8Ω and open circuit)

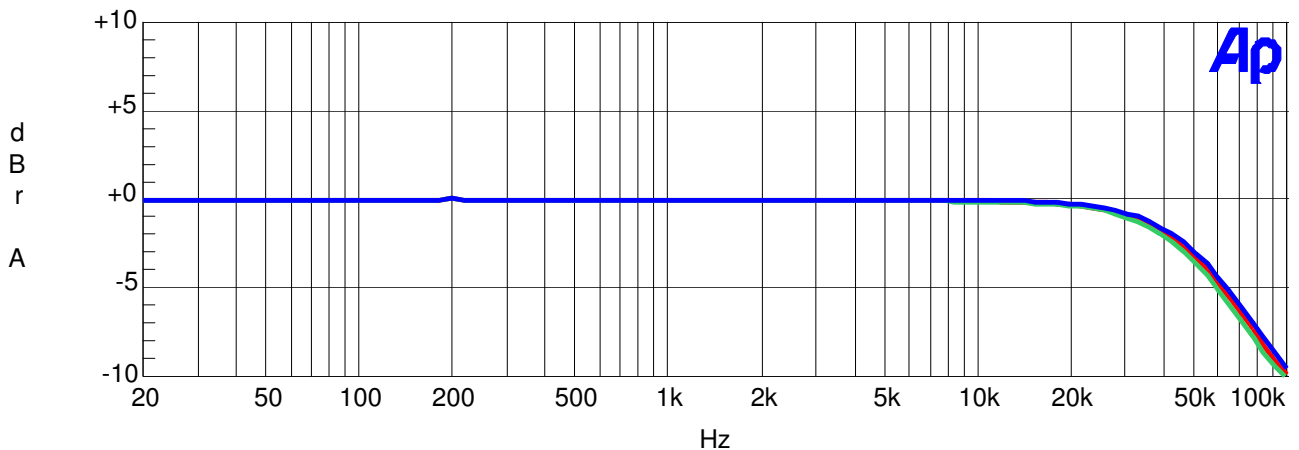

From top to bottom: open circuit, 8Ω, 4Ω

### Output Impedance

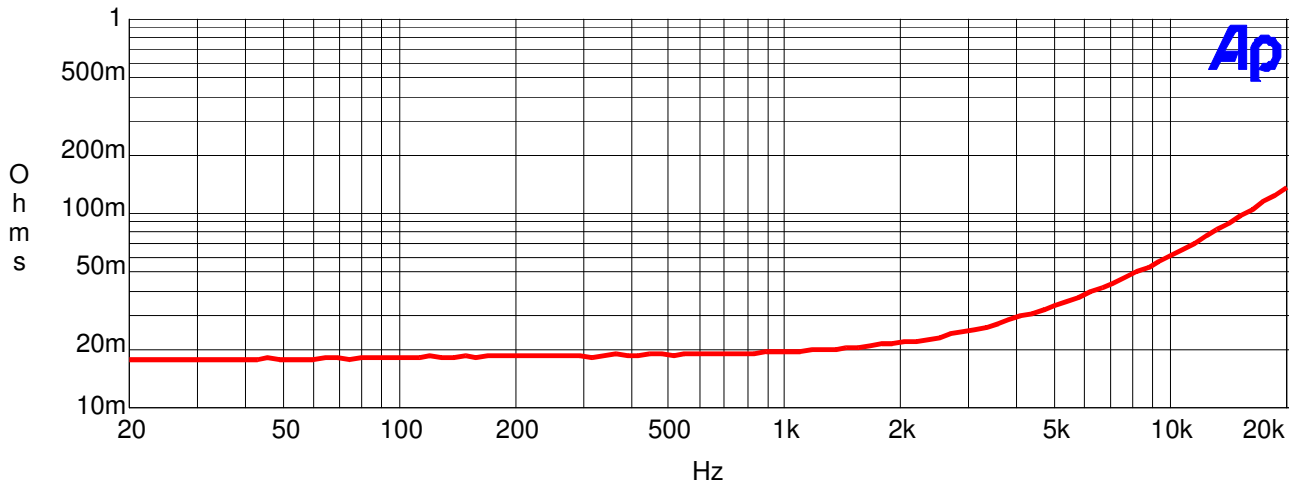

### 19+20kHz IMD (10W, 4 ohms)

