

## High Efficiency High Power Audio SMPS

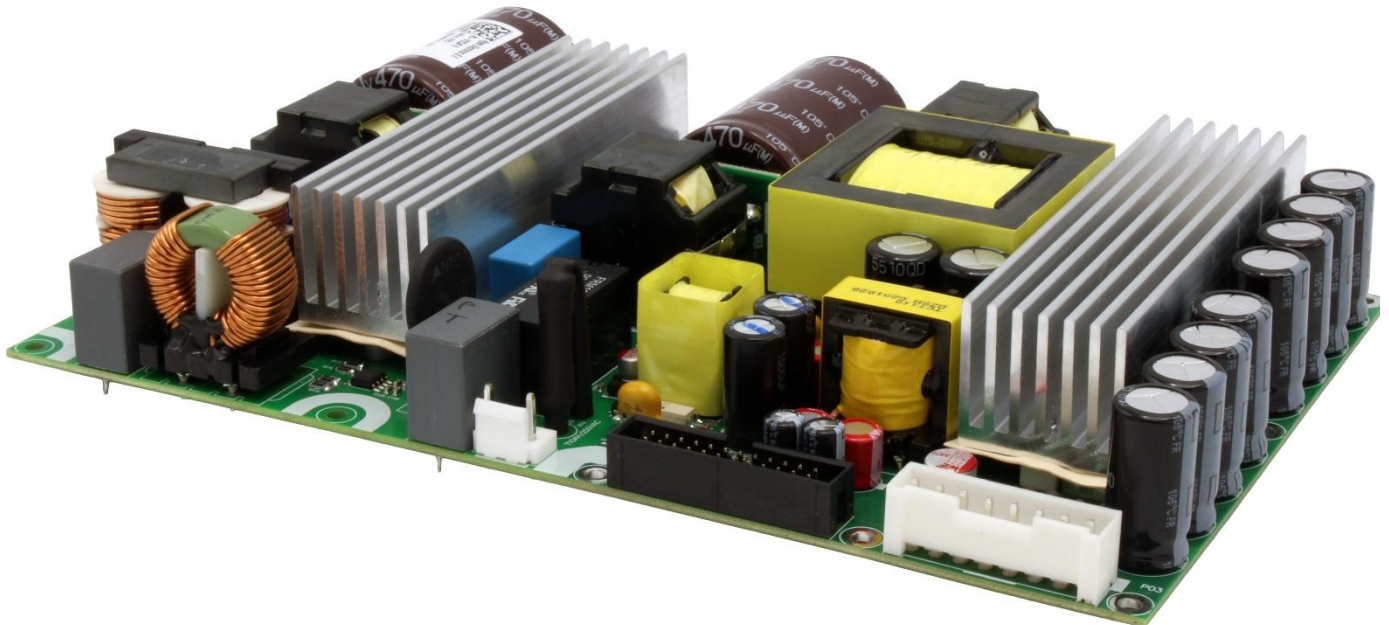

Image is for illustrative purposes only. Please refer to product description.

### Highlights

- High efficiency
- Universal mains voltage input with Power Factor Correction
- Extremely small form factor
- Low EMI
- 4 variants available
- Tight output voltage regulation

### Features

- Advanced over current protection
- Remote controlled operation
- Selectable Auxiliary/VDR output voltage
- Low weight: T.B.D.
- Compact design: 205 x 130 x 38mm

### Applications

- Multichannel amplifiers, including 1U chassis
- Active loudspeakers

### Introduction

The PS1000 is a high power, high-efficiency Safety Class 2 switch mode power supply intended for use with our DSA, NCORE®, NCORE®x and Nilai line of amplifiers. Key features are Active Power Factor correction, on-board 5V 2013 ERP Lot 6 0.5W ERP compliant standby converter, symmetrical auxiliary supply with arbitrary power sharing, high efficiency, small form factor and a low EMI signature.

All output voltage rails of PS1000 are regulated and are thus invariant of mains input voltage. All outputs are also fully protected against short circuit and overload. The main output rails are fitted with a foldback over power protection which reduces the output voltage rails during extreme peak output power events without shutdown

## Contents

HIGHLIGHTS.....	1
FEATURES.....	1
APPLICATIONS.....	1
INTRODUCTION.....	1
CONTENTS.....	2
<b>1 SAFETY PRECAUTIONS .....</b>	<b>3</b>
<b>1 PRÉCAUTIONS DE SÉCURITÉ.....</b>	<b>3</b>
<b>2 THE PS1000 SERIES.....</b>	<b>4</b>
2.1 HALF-BRIDGE AMPLIFIERS (NCx700, DSA254).....	4
<b>3 ELECTRICAL SPECIFICATIONS.....</b>	<b>5</b>
3.1 POWER SPECIFICATIONS.....	5
3.2 STANDBY POWER SUPPLY.....	5
3.3 GENERAL PERFORMANCE DATA.....	5
3.4 TIMING SPECIFICATIONS.....	6
<b>4 ENVIRONMENTAL SPECIFICATIONS.....</b>	<b>6</b>
4.1 HEAT DISSIPATION / EFFICIENCY CURVE.....	7
<b>5 PRODUCT MARKINGS .....</b>	<b>7</b>
<b>6 IO SPECIFICATIONS .....</b>	<b>8</b>
6.1 POWER SUPPLY ENABLE.....	8
6.2 AUX/VDR SELECT.....	8
6.3 DC-ERROR.....	8
6.4 POWER GOOD.....	9
6.5 FATAL.....	9
6.6 AC_DETECT.....	9
6.7 OTP_WARNING.....	9
6.8 TEMPERATURE READOUT.....	10
6.9 BOOTSTRAP DRIVER VOLTAGE (V <sub>DR</sub> ).....	11
<b>7 CONNECTOR PINOUTS .....</b>	<b>12</b>
7.1 AC CONNECTOR SPECIFICATION.....	12
7.2 HYPLEX UNIVERSAL SUPPLY INTERFACE.....	13
7.3 MAIN OUTPUT CONNECTOR.....	13
<b>8 GENERAL PERFORMANCE DATA.....</b>	<b>14</b>
<b>9 DIMENSIONS.....</b>	<b>15</b>
9.1 TOP VIEW.....	15
9.2 SIDE VIEW.....	16
<b>10 SAFETY COMPLIANCE.....</b>	<b>17</b>
<b>11 REVISIONS.....</b>	<b>18</b>
<b>12 DISCLAIMER.....</b>	<b>18</b>

## 1 Safety precautions



This module operates at mains voltage and carries hazardous voltages at accessible parts. These parts may never be exposed to inadvertent touch. Observe extreme care during installation and never touch any part of the unit while it is connected to the mains.

Disconnect the unit from the mains and allow all capacitors to discharge for 10 minutes before handling it.



Attention: Observe precautions for handling electrostatic sensitive devices. This module uses semiconductors that can be damaged by electrostatic discharge (ESD).

Damage due to inappropriate handling is not covered by warranty.

This product has no user-serviceable parts.



This symbol indicates the presence of hazardous voltages at accessible conductive terminals on the board. Parts that are not highlighted in red may also carry voltages in excess of 200 Vdc!

**Warning:** To reduce the risk of fire or electric shock, do not expose this apparatus to rain or moisture.

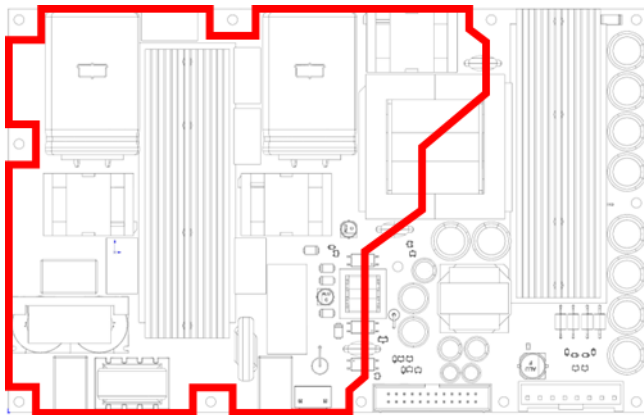

This is a Safety Class 2 device. When mounting the module in an enclosure, a minimum safety distance of 6mm from the PS1000 to all possible conducting parts must be ensured to keep compliance with Safety Class 2. All parts enclosed by the red line carry hazardous voltages and are considered ES3 and are connected to mains voltage. This includes parts on the top and the bottom of the board.

PS1000 is supplied without standoffs. An isolation sheet with a minimum thickness of 0.4mm must be mounted underneath PS1000 for mains isolation. A minimum of 6mm distance from the top of the module to any conducting parts of an enclosure, or the use of an isolation sheet with a minimum thickness of 0.4mm above the module is required for mains isolation.

## 1 Précautions de sécurité

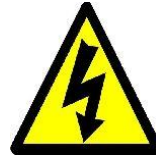

Ce module est sous tension secteur et certaines de ses pièces accessibles sont sous une tension dangereuse. Ces pièces doivent dans tous les cas être protégées contre contacts accidentels. Lors de l'installation, une prudence extrême s'impose. Ne jamais toucher les pièces du module quand celui-ci est relié au secteur. Isoler l'appareil du secteur et attendre 10 minutes pour laisser à tous les condensateurs le temps de se décharger avant de le manipuler.



Attention : Respecter les consignes de sécurité pour la manipulation d'appareils sensibles aux courants électrostatiques. Ce module est pourvu de semi-conducteurs qui peuvent être endommagés par les décharges électrostatiques (DES).

Les dommages causés par un usage non approprié sont exclus de la garantie.

Ce produit ne contient aucune pièce devant être entretenue par l'utilisateur.



Ce symbole indique la présence de tensions dangereuses aux broches de raccordement accessibles sur la carte. Les pièces non marquées en rouge peuvent être elles aussi sous une tension supérieure à 200 VCC.

**Avertissement:** Pour réduire les risques de choc électrique, ne pas exposer cet appareil à la pluie ou l'humidité.

1. Read these instructions.
2. Keep these instructions.
3. Heed all warnings.
4. Follow all instructions.
5. Do not use this apparatus near water.
6. Protect the power cord from being walked on or pinched, particularly at plugs, convenience receptacles, and the point where they exit from the application.
7. Only use attachments/accessories specified or approved by the manufacturer.
8. Unplug this apparatus during lightning storms or when unused for long periods of time.
9. Refer all servicing to qualified service personnel. Servicing is required when the apparatus has been damaged in any way, liquid has been spilled or objects have fallen into the apparatus, the apparatus has been exposed to rain or moisture, does not operate normally or has been dropped.
10. Don't run any cables across the top or the bottom of the module. Apply fixtures to cables to ensure that this is not compromised.
11. Observe a minimum clearance of 6mm with all possible conducting parts (housing etc.).
12. Natural convection should not be impeded by covering the module (apart from the end applications housing).
13. This product is to be used with Hypex amplifier modules only.
14. Before using this product, ensure all cables are correctly connected and the power cables are not damaged. If you detect any damage, do not use the product.
15. Changes or modifications not expressly approved by Hypex Electronics will void compliance and therefore the user's authority to operate the equipment.
16. Service or modifications by any person or persons other than by Hypex Electronics authorized personnel voids the warranty.

## 2 The PS1000 Series

The SMPS1200 series is a range of Switch Mode Power Supplies. In the next table there is an overview of the different models, their output voltages and application.

Model	Main rails output	For use with amplifiers (examples)
PS1000R45	2x 45Vdc	DSA254, NCx1400, NCx500
PS1000R54	2x 54Vdc	
PS1000R75	2x 75Vdc	
PS1000R85	2x 85Vdc	

The maximum number of modules which can be connected to PS1000 is limited by the output power of the supply, as well as the output current of the Vaux and VDR outputs. Please refer to the amplifier's datasheet for more information.

### 2.1 Half-bridge amplifiers (NCx500, DSA254)

PS1000 does not feature 2-quadrant operation and is thus unable to handle large reverse currents generated by half bridge amplifier modules. When using PS1000 with half bridge amplifiers, it is strongly advised to reverse the phase of both input and output of half the amplifier channels used for LF audio content.

### 3 Electrical Specifications

#### 3.1 Power Specifications

Parameter	Conditions	Symbol	Min	Typ	Max	Unit	Note
Line Input Voltage	-	V <sub>B</sub>	100-240 +/- 10%			V <sub>ac</sub>	1)
Line Input Frequency	-	f	47		63	Hz	1)
Fuse rating	250Vac, slow blow			10		A	2)

**Note 1:** Operation beyond these limits may result in irreversible damage.

**Note 2:** Fuse is soldered on the PCB and is therefore not user replaceable.

#### 3.2 Standby Power Supply

The standby supply is immediately active upon connection to the mains and can therefore be used to power external control circuitry and to operate the PS Enable pin

Parameter	Remarks	Symbol	Min	Typ	Max	Unit	Note
Output voltage	-	V <sub>OUT</sub>	5,1	5,2	5,3	V <sub>dc</sub>	1)
Output Current	Continuous	I <sub>OUT,MAX</sub>			1	A <sub>dc</sub>	
Output Current	For ERP compliance	I <sub>OUT,ERP</sub>			45	mA	
External Capacitance	-	-			4700	μF	
Efficiency	Full Power	η		71		%	
Standby Power	No Load	P <sub>STB</sub>			0.2	W	
Output Voltage Ripple	Full Power	V <sub>RIPPLE</sub>			0,1	V	

**Note 1:** Protected against short circuit and overload, auto recovery when overcurrent condition is removed

#### 3.3 General Performance Data

Parameter	Remarks	Symbol	Min	Typ	Max	Unit	Note
Output Voltage Main	R45, symmetric	V <sub>OUT</sub>		2x45		V <sub>dc</sub>	1)
	R54, symmetric	V <sub>OUT</sub>		2x54		V <sub>dc</sub>	1)
	R75, symmetric	V <sub>OUT</sub>		2x75		V <sub>dc</sub>	1)
	R85, symmetric	V <sub>OUT</sub>		2x85		V <sub>dc</sub>	1)
Output Power Main		P <sub>OUT</sub>		1000		W	
Output Voltage V <sub>AUX_Low</sub>	Low voltage setting	V <sub>AUX</sub>		2x15		V <sub>dc</sub>	1)
Output Voltage V <sub>AUX_High</sub>	High voltage setting	V <sub>AUX</sub>		2x18		V <sub>dc</sub>	1)
External capacitance V <sub>AUX</sub>	Per rail		-	-	1000	μF	
Output Current V <sub>AUX</sub>	All versions, per rail	I <sub>AUX</sub>	-	-	2	A	1), 2)
Output Voltage V <sub>DR_Low</sub>	Low voltage setting	V <sub>OUT,Vdr</sub>	-	15	-	V <sub>dc</sub>	1)
Output Voltage V <sub>DR_High</sub>	High voltage setting	V <sub>OUT,Vdr</sub>	-	18	-	V <sub>dc</sub>	1)
Output Power V <sub>AUX</sub> /V <sub>DR</sub>	Combined, arbitrary power sharing	I <sub>OUT,Vdr</sub>	-	-	32	W	2)
In-rush current	10Ω In-rush NTC, worst-case	I <sub>inrush</sub>			46	A	
Efficiency	Full power	η	93.5			%	
Idle Losses	230 Vac, 50 Hz	P <sub>0</sub>	-	5	-	W	
Power consumption	Depending on load	P <sub>max</sub>			1120	W	

**Note 1:** Protected against short circuit and overload, auto recovery when overcurrent condition is removed

**Note 2:** Total combined output power of the VDR and V<sub>AUX</sub> outputs is 30W. This power can be freely allocated across the three outputs, depending on system requirements. Each output is capable of supplying the full 32W continuously. Please refer to the amplifier datasheets for the required VDR power of the system.

**Note 3:** V<sub>AUX</sub> and VDR are regulated at the same voltage, with two selectable voltage settings. Please refer to 6.2 for more information

### 3.4 Timing Specifications

These timings are measured at room temperatures, approximately 21°C. Mains voltage start/stop angle 0°

Parameter	Conditions	Symbol	Min	Typ	Max	Unit	Note
Standby start up delay	Time mains presence, till standby supply is within operational limits	230V		15		ms	
		115V		20		ms	
Switching start up delay	Time mains presence, till all power supplies are within operational limits	230V		300		ms	
		115V		500		ms	
Shutdown delay	Time between PS_ENABLE deactivation or protection activation and deactivation of main LLC				1	ms	
AC detect delay	Time between mains removal and AC_DETECT signal indication	230V		85		ms	1)
		115V		75		ms	

**Note 1:** The AC\_Detect signal indication of PS1000 is not used internally to switch of any supply rails in PS1000, it is purely an indication of loss of mains voltage for customer use.

## 4 Environmental Specifications

Parameter	Conditions	Symbol	Min	Typ	Max	Unit	Note
Ambient Temperature	Storage		-25	-	70	°C	
	Operation passive cooling		0	-	50	°C	
	Operation active cooling		0	-	60	°C	1)
Heat-sink Temperature		$T_{h,max}$			98	°C	2)
Humidity	Max 85 percent relative humidity, non-condensing.						

**Note 1:** airflow  $\geq 1\text{m/s}$

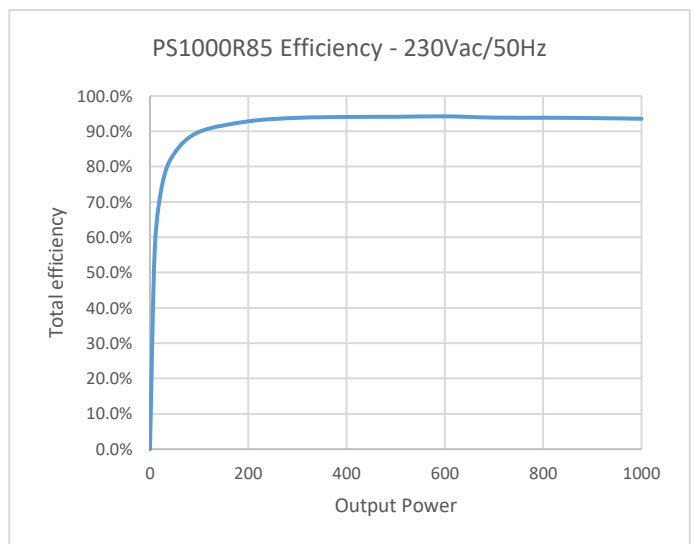
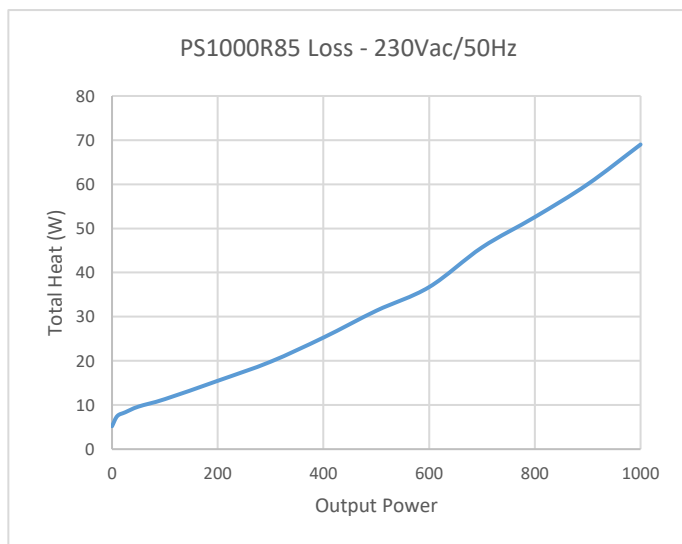
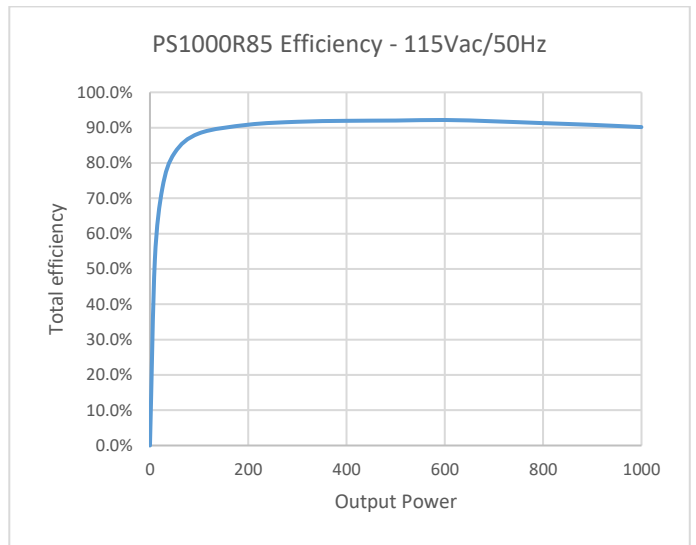
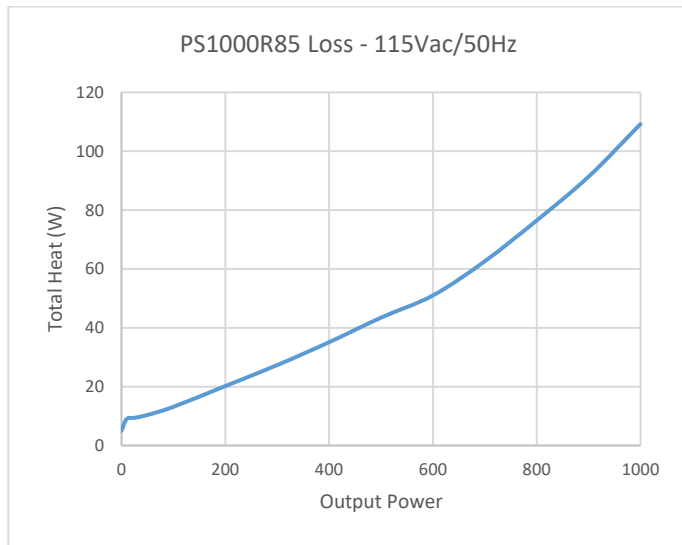

**Note 2:** This module features a thermal shutdown mechanism to protect against over temperature. This mechanism is meant to be a final protection. Please apply adequate cooling measures to prevent over temperature.

### 4.1 Heat dissipation / Efficiency curve

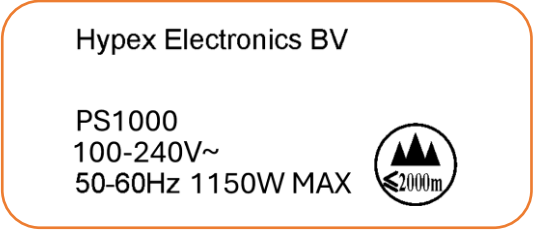

## 5 Product Markings

This module has two marking stickers applied.

Model sticker example	Identification sticker example
	

## 6 IO Specifications

### 6.1 Power Supply Enable

By asserting the PS Enable pin of the Hypex Universal Supply Interface connector the Main-SMPS is enabled. The Standby-SMPS is enabled from the moment that the module is connected to mains. Therefore, the Standby-SMPS can be used to activate the Main-SMPS.

Parameter	Remarks	Symbol	Min	Typ	Max	Unit	Note
SMPS enabled	Logic High level		3,3	-	12	Vdc	1)
SMPS in standby	Logic Low level		-	-	0.8	Vdc	

**Note 1:** The current (A) drawn can be calculated as follows:  $(V_{pin} - 0.7) / 10000$

### 6.2 Aux/VDR Select

As standard, the output voltage of the Vaux and VDR outputs are set to nominal 15V. Depending on the requirements of the connected Hypex amplifier module and system requirements, a higher Vaux/VDR voltage can be desired. By tying the Aux/VDR Select pin to GND on the system motherboard, the voltage of the Vaux and VDR outputs are raised to a nominal 17V. This setting may not be changed during operation and must be fixed on the system motherboard.

Aux/VDR select setting	Remarks	Symbol	Min	Typ	Max	Unit	Note
Open circuit	Vaux/VDR low voltage		14	15	15.5	Vdc	
GND	Vaux/VDR high voltage		17	18	18.5	Vdc	

### 6.3 DC-Error

In the event of a critical failure occurring in the connected amplifier, PS1000 needs to be switched off rapidly. PS1000 provides a single DC Error Input designated for Hypex amplifiers. The DC Error Input is latched and will not auto-recover. To reset the DC Error the module must be disconnected from mains for at least 1 minute to allow the primary capacitors to drain.

**Note:** this input is incompatible with UcD180HG and UcD400HG modules.

Parameter	Conditions	Symbol	Min	Typ	Max	Unit	Note
No error condition	Use open collector		-	-	-	Vdc	1)
DC Error	Pull pin to Gnd		-	Gnd	-	Vdc	1), 2)

**Note 1:** DC-Error must be pulled to ground to activate. Hypex amplifier modules use open collector output (DC-Error pin) to achieve this. Multiple DC-error output signals from Hypex amplifiers can be tied to the PS1000 DC-Error input in parallel without further circuitry.

**Note 2:** current ~2.5mA

## 6.4 Power Good

Power Good is an open collector output indicating both the main and auxiliary SMPS are in normal operating conditions and have reached their intended output voltage level.

Parameter	Remarks	Symbol	Min	Typ	Max	Unit	Note
Collector voltage	Open collector output		-	-	50	V	
Collector current	Open collector output		-	-	100	mA	

## 6.5 FATAL

FATAL is an open collector output indicating a critical, latching fault condition. This can be caused by an amplifier DC\_Error, overvoltage protection on the main supply output (can be caused by supply pumping if used with single ended class D amplifiers) or critical overtemperature on the mains transformer.

Parameter	Remarks	Symbol	Min	Typ	Max	Unit	Note
Collector voltage	Open collector output		-	-	50	V	
Collector current	Open collector output		-	-	100	mA	

## 6.6 AC\_DETECT

AC\_Detect is an open collector output indicating the presence of an AC mains input voltage. AC\_Detect goes high after mains removal.

Parameter	Remarks	Symbol	Min	Typ	Max	Unit	Note
Collector voltage	Open collector output		-	-	50	V	
Collector current	Open collector output		-	-	100	mA	

## 6.7 OTP\_WARNING

PS1000 is fitted with multiple thermal protection circuits which can turn off the main and auxiliary SMPS. OTP\_WARNING is an open collector output which is pulled low to indicate that the temperature on one of the thermal protection circuits is nearing the protection level. This signal can be used to either ramp up active cooling or reduce system output power to prevent thermal turn-off.

Parameter	Remarks	Symbol	Min	Typ	Max	Unit	Note
Collector voltage	Open collector output		-	-	50	V	
Collector current	Open collector output		-	-	100	mA	

## 6.8 Temperature Readout

An NTC is placed underneath the main SMPS transformer and can be used to monitor the temperature. The NTC is connected to GND and accessible via the Hypex Universal Supply Interface connector. The characteristics of the NTC are stated in the datasheet of the NTC manufacturer.

Parameter	Remarks	Symbol	Min	Typ	Max	Unit	Note
Resistor value	100 °C – 25 °C		0.9	-	10	kΩ	
Permissive Operating Current	25°C				0.31	mA	

**NTC type:** NCP18XH103J03RB

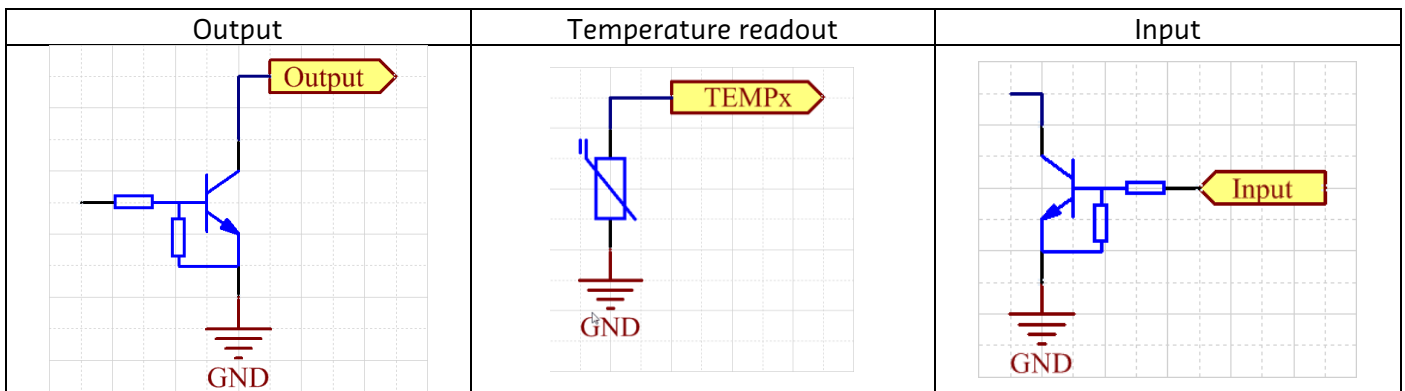

## 6.9 Bootstrap Driver Voltage ( $V_{DR}$ )

PS1000 provides a regulated Bootstrap Driver Voltage ( $V_{DR}$ ) which is used to power the driver circuit of Hypex amplifier. Most Hypex amplifier modules need the  $V_{DR}$  voltage referenced to the negative supply rail (HV-). In order to achieve this, the  $V_{DR-}$  should be connected to the main negative supply rail (HV-) at the amplifier side.

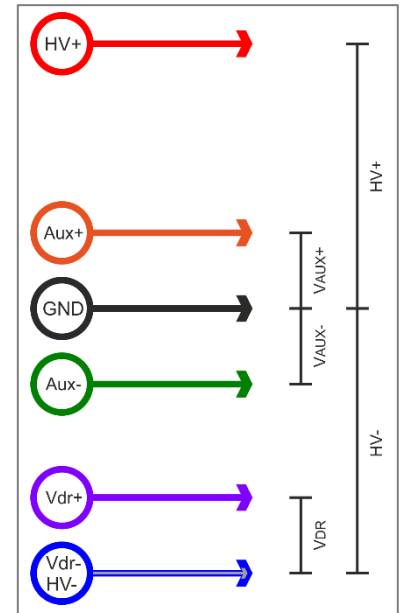

## 7 Connector Pinouts

This chapter describes the functional connectors of the power supply module. A connector not stated in this chapter is only used for production or quality control and must remain unconnected in the end user appliance. The arrow points towards pin1 of the connector.

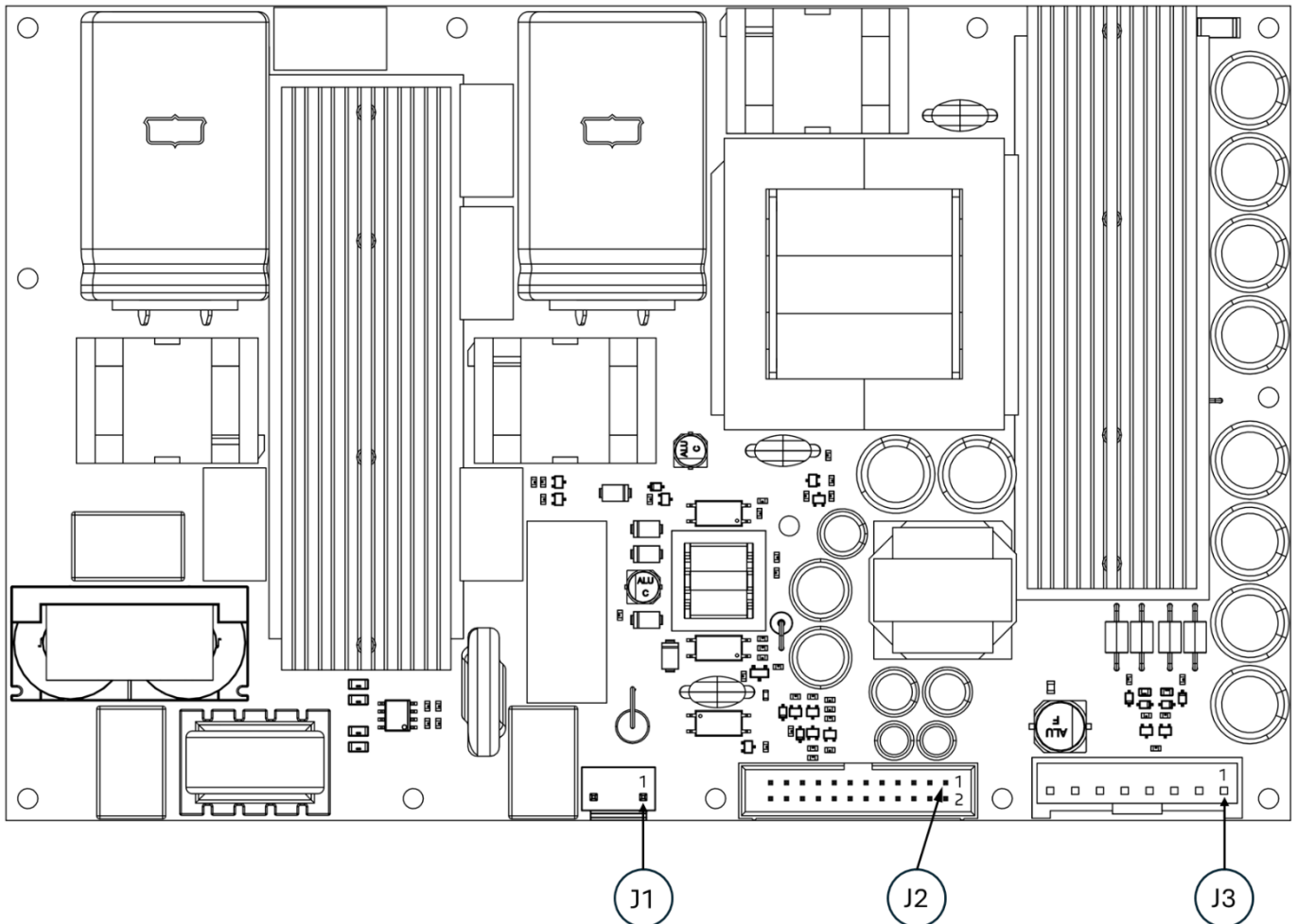

### 7.1 AC Connector Specification

Pin	Direction	Function	Remarks
J1.1	Input	Mains input	Neutral AC
J1.3	Input	Mains input	Phase AC

**Connector type equivalent:** B2P3-VH(LF)(SN).

## 7.2 Hypex Universal Supply Interface

Pin	Direction	Function	Remarks
J2.1	Output	Vaux,Pos	Positive regulated auxiliary supply
J2.2	Output	Vaux,Pos	
J2.3	Output	Vaux,Neg	Negative regulated auxiliary supply
J2.4	Output	Vaux,Neg	
J2.5	-	GND	Ground
J2.6	-	GND	
J2.7	Output	Vout,standby	Regulated standby supply
J2.8	Output	Vout,standby	
J2.9	-	GND	Ground
J2.10	-	GND	
J2.11	Input	Aux/VDR Select	Aux/VDR output voltage selection
J2.12	Input	PS Enable	Power supply enable
J2.13	Output	Power Good	Power supply stable indicator
J2.14	Input	DC Error	DC Error input from amplifiers
J2.15	Output	FATAL	Critical, latching fault indicator
J2.16	Output	AC Detect	AC mains status indicator
J2.17	Output	OTP Warning	Overtemperature protection pre-warning indicator
J2.18	Output	Thermal	Transformer temperature readout
J2.19	Reserved	Reserved	Not connected
J2.20	Reserved	Reserved	Not connected
J2.21	Reserved	Reserved	Not connected
J2.22	-	GND	Ground
J2.23	n.c.	SDA (I <sup>2</sup> C)	Not connected
J2.24	n.c.	SCL (I <sup>2</sup> C)	Not connected

**Connector type equivalent:** T821124A1S100CEU

**Contact material:** Brass, gold flash over nickel

## 7.3 Main output connector

Pin	Direction	Function	Remarks
J3.1	Output	HV+	Positive supply rail
J3.2	Output	HV+	
J3.3	-	GND	Ground
J3.4	-	GND	
J3.5	Output	HV-	Negative supply rail
J3.6	Output	HV-	
J3.7	Output	Vdr-	Negative bootstrap driver voltage
J3.8	Output	Vdr+	Positive bootstrap driver voltage

**Connector type:** B8P-VH-FB-B(LF)(SN).

## 8 Typical performance data

T.B.D.

## 9 Dimensions

PS1000 is supplied without standoffs.

### 9.1 Top view

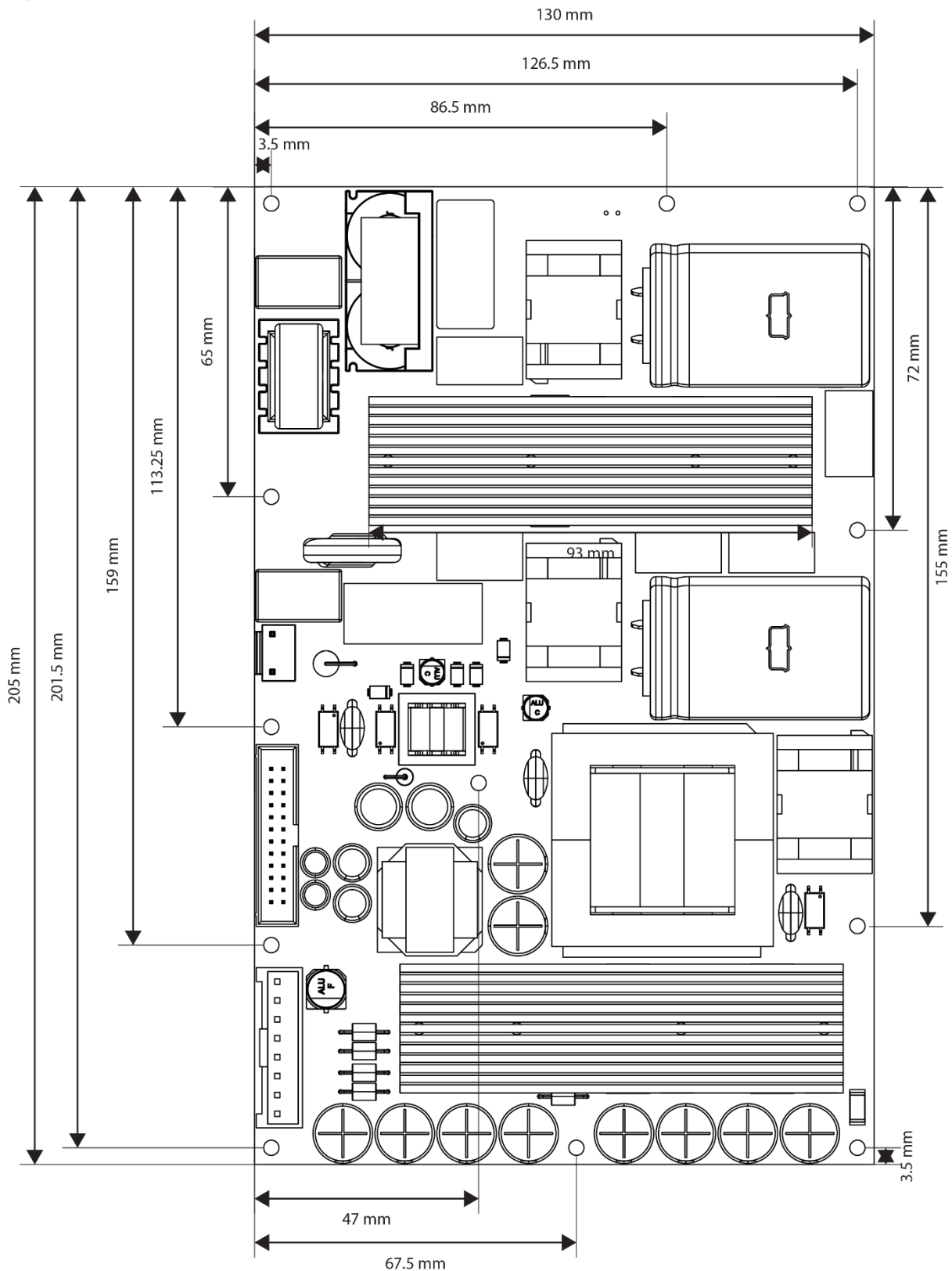

## 9.2 Side view

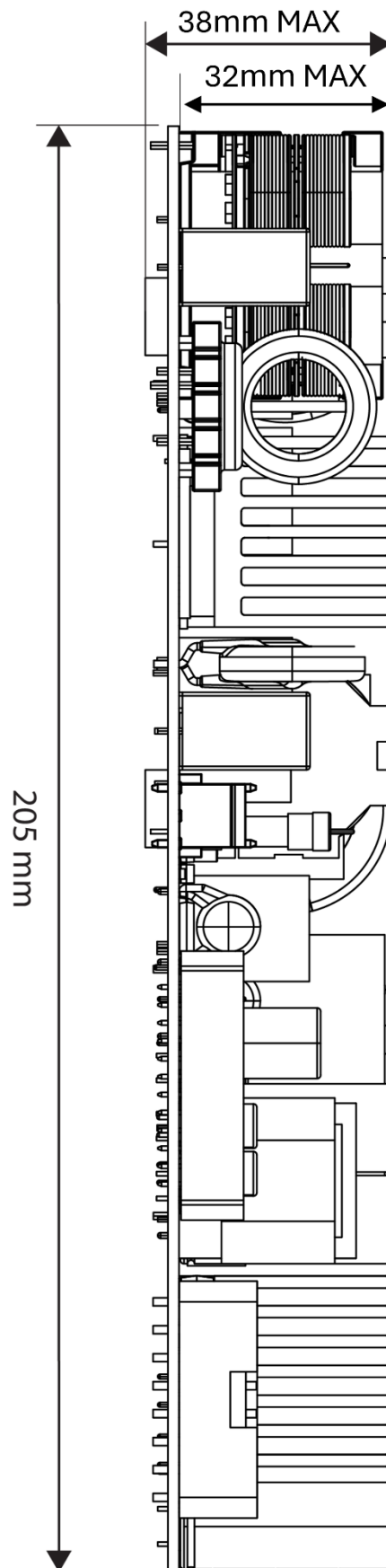

## 10 Safety compliance

The PS1000R45, PS1000R54, PS1000R75 and PS1000R85 revision 0100 and higher are safety tested according to the following standards:

- IEC 62368-1:2018 + A11:2020
  - National deviations for CENELEC countries
  - National deviations for USA / Canada
  - National deviations for Australia / New Zealand
  - National deviations for China
  - National deviations for Japan
  - National deviations for Korea
  - National deviations for Singapore
- IEC 62368-1:2023
  - National deviations for CENELEC countries
  - National deviations for USA / Canada
  - National deviations for Japan

### Relevant standards

The PS1000R45, PS1000R54, PS1000R75 and PS1000R85 revision 0100 and higher fulfil the requirements of:

- IEC62368-1:2018 + A11:2020
- IEC62368-1:2023
- CSA/UL 62368-1:2019
- CSA/UL 62368-1:2025
- AS/NZS 62368.1:2022
- GB 4943.1-2022
- J62368-1(2023)
- KC 62368-1(2021-08)

### Test procedure

- CB scheme IEC62368-1:2018 + A11:2020
  - Test laboratory: Intertek SEMKO
  - Ref Certif. No.: SE-119558
- CB scheme IEC62368-1:2023
  - Test laboratory: Intertek SEMKO
  - Ref Certif. No.: SE-119559

### ETL listing

The PS1000R45, PS1000R54, PS1000R75 and PS1000R85 are ETL listed components for the USA (UL 62368-1:2025 Ed.4) and Canada (C22.2#62368-1:2025 Ed.4)

## 11 Revisions

Document revision	Module revision	Change log	Date
01	0002	First draft	2025-09-11
02	0003	Added loss/efficiency graphs for R85	2025-09-26
03	0004	Added ratings label	2026-01-05
04	0004	Updated measurements	2026-02-27
05	0006	Updated mechanical drawings Updated measurements	2026-03-27
06	0006	Updated environmental specifications Corrected typo in table under 2	2026-05-04
07	0100	Added safety compliance information	2026-06-03

## 12 Disclaimer

**All products, product specifications and data are subject to change without notice to improve reliability, function or design or otherwise.**

**Hypex Electronics BV, its affiliates, agents, and employees, and all persons acting on its or their behalf (collectively, "Hypex Electronics"), disclaim any and all liability for any errors, inaccuracies or incompleteness contained in any datasheet or in any other disclosure relating to any product.**

**This subassembly is designed for use in music reproduction equipment only. No representations are made as to fitness for other uses. Except where noted otherwise any specifications given pertain to this subassembly only. Responsibility for verifying the performance, safety, reliability and compliance with legal standards of end products using this subassembly falls to the manufacturer of said end product.**

**LIFE SUPPORT POLICY: Use of Hypex products in life support equipment or equipment whose failure can reasonably be expected to result in injury or death is not permitted except by explicit written consent from Hypex Electronics BV.**