

# WIRING DIAGRAM Hypex UCD250LP

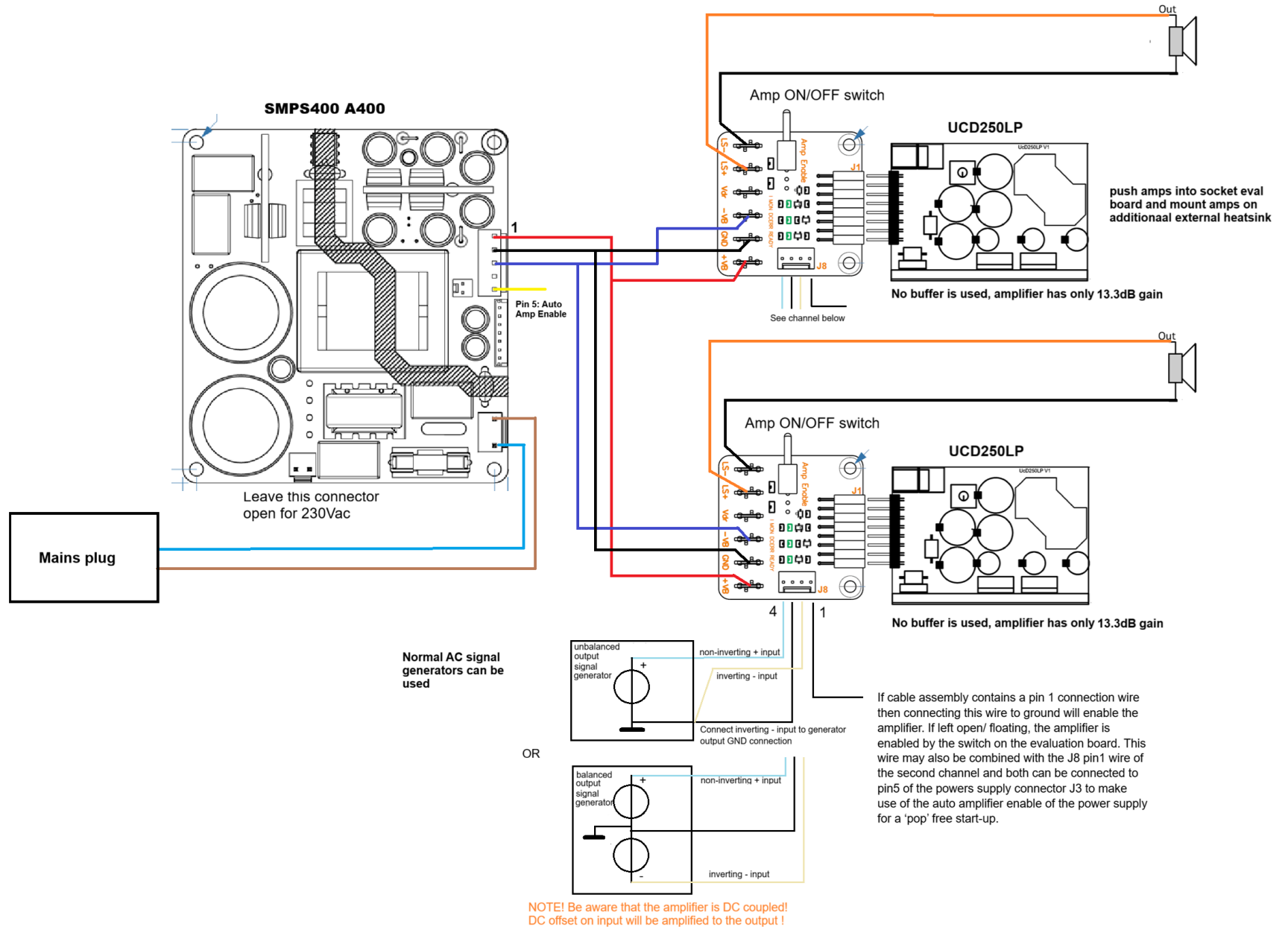

# WIRING DIAGRAM Hypex UCD250LP

Possible UCD250LP OEM backplane set-up with buffer

Figure 1: Connector pinning Ucd250LP.

Figure 1: Connector pinning Ucd250LP.

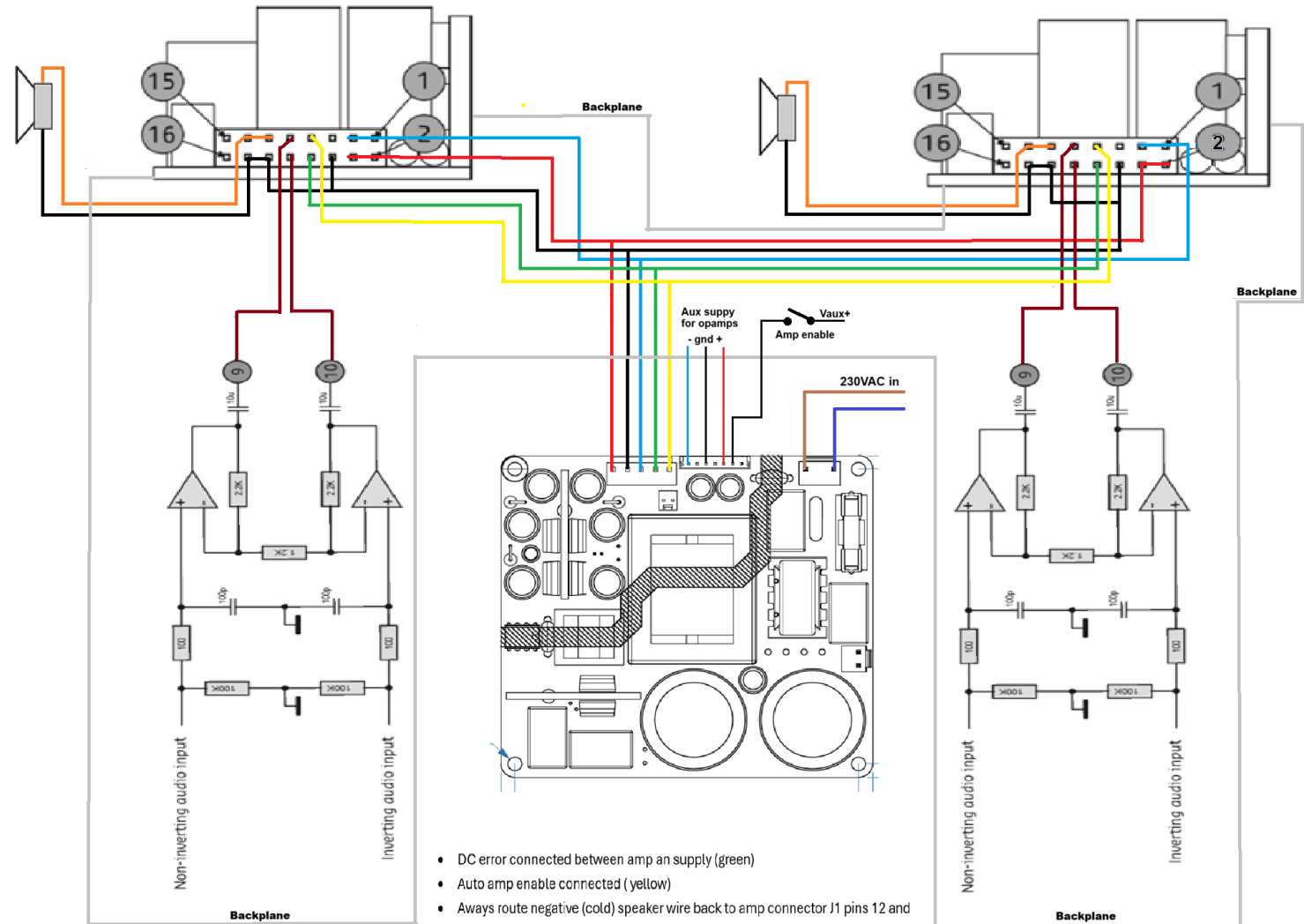

- DC error connected between amp an supply (green)
- Auto amp enable connected (yellow)
- Always route negative (cold) speaker wire back to amp connector J1 pins 12 and 14, keep hot and cold speaker wires in parallel up to amp connector J1 pins. Do not use a general ground connection anywhere on a backplane.
- Pins 6,12,14 of amp connectors can be directly connected to one large back plane ground, directly at the connector.
- Amps enable controlled via input on SMPS400 supply connector J5 pin 2.